

SCAFFOLD

Helping to support and maintain the world of origami

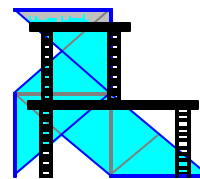

Scaffold Web Site Delayed

Once again, Scaffold is being sent out through e-mail. Several family deaths and the loaning out of some reference materials has delayed the creation of the Scaffold web site. Soon, future issues will be available to subscribers online, with a simple e-mail message announcing the new issue and its specific location.

Back Issues

All back issues of Scaffold can be found online at <http://www.origami4you.com>.

New Books

I have not seen any new books this month, but I am eagerly awaiting the release

CONTENTS

<i>Back Issues</i>	1
<i>New Books</i>	1
<i>Submissions</i>	2
<i>Book Review</i>	2
<i>The Models</i>	2
<i>Dachshund</i>	3
<i>Octohedron Skeleton</i>	7

of A PLETHORA OF POLYHEDRA IN ORIGAMI by John Montroll. It is scheduled for release during March 2002 but seems to be running a little late.

I hope this book will be reviewed in the next issue.

Submissions

Scaffold tries to provide a place for origami designers to show off their designs to the world folding community. For that to work, folders have to send in their diagrams. Scaffold can accept most electronic formats, but DXF (generic CAD format) results in very small file sizes.

All models and diagrams remain the property of their designers and Scaffold will not change or edit diagrams (with the exception of clarifying scans) and will publish all designs submitted. Crease-fold diagrams are also accepted.

Diagrams can be submitted electronically by sending e-mail to scaffold1@aol.com. Paper

diagrams can be sent to:
Joshua Koppel
PO Box 641374
Chicago, IL 60664-1374
USA

Submissions should be accompanied by a statement saying that you wish them to appear in Scaffold.

Book Review

ORIGAMI SAILBOATS is the fourth origami book by Lew Rozelle. This book is similar in style to his earlier book, ORIGAMI ROCKETS and people who did not like ROCKETS will probably not like SAILBOATS.

ORIGAMI SAILBOATS is not really a book for people looking for a collection of interesting models, but is really more for showing how simple changes can create a whole line of new models. I think this is a good book for folders who either create their own designs or who want to create their own designs.

One of the keystones of this book is that the author

has taken a traditional origami boat that involves turning the boat inside-out, and created a new folding method that no longer involves the often-troublesome maneuver. Unfortunately, step 6 of the new diagrams has a couple of mistakes. It shows a valley-fold running straight across the length of the paper when it should show two bends. This can be figured out by looking at step 7.

ORIGAMI SAILBOATS is written with very clear drawings and diagrams for quite a few models, many of which look better in water than on dry land (rudders can get in the way of displaying some of the models).

Overall, I like this book but I recognize that many will not. The biggest problem with this book is not the fault of the author, but is the fault of the publisher. I speak of the \$19.95 (US) price that many folders will find too steep for the contents.

ORIGAMI SAILBOATS is published by St. Martin's Griffin and should be available wherever fine origami books are sold. (ISBN 0-312-26906-4 \$19.95 (US))

The Models

This month we have an

excellent dog model sent in by Jim Adams. To round things out we have another Sonobe unit variation from the 1980s as well as a brand-new geometric unit.

Dachshund

Another fine model from Jim Adams. I love dachshunds and I love this model. This one not only captures the body and head well but ,unlike most others, it gets the long, thin tail correct. More designs by Mr. Adams can be found at:

<http://members.aol.com/jeada ms1>.

Skeleton of Octahedron

I was assembling some polyhedron skeletons and decided that I did not like the octahedron in the book I was using. Moments later I had this model. Five minutes later I had three more variations with different styles of locks.

Sonobe Unit: Zebra

This is another variation of the classic Sonobe Unit. This one results in tapered stripes on the face of the unit. It is a slight variation of my previous unit Propeller which can be found in issue 10 of Scaffold which can be found at:

<http://www.origami4you.com/scaff10.pdf>

DACHSHUND

- Thin paper or foil is recommended.
- Start with colored bird base.
- A 10 inch square makes a 5 1/2 inch long model.

Jim Adams

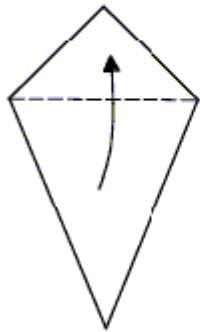

1. Start with a colored bird base. Fold top layer only.

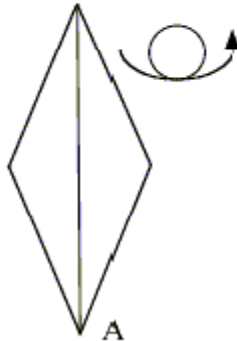

2. "A" marks the end with multiple flaps.

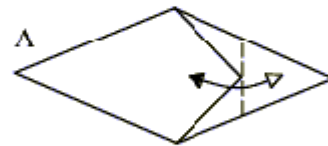

3.

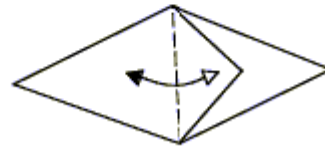

4.

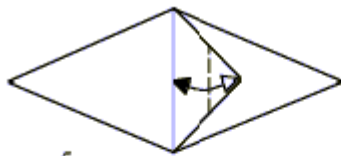

5.

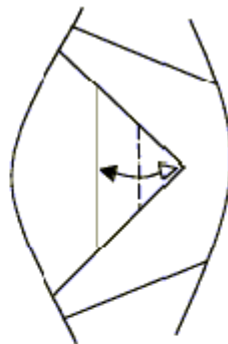

6. This is a close-up view of the center flap.

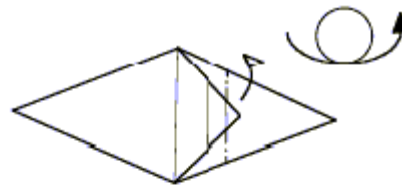

7. Fold bottom flap only.

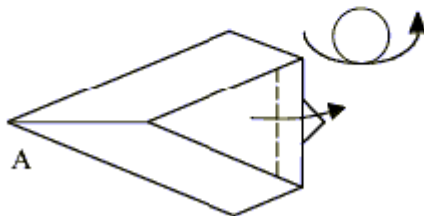

8. Fold is on existing crease.

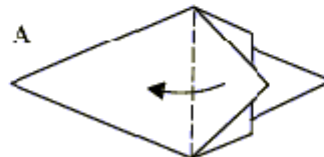

9.

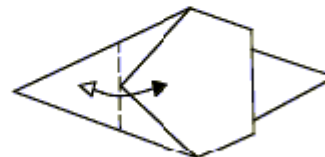

10. Crease all layers.

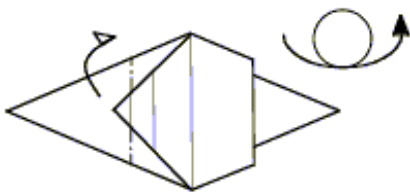

11. Fold bottom flaps only.

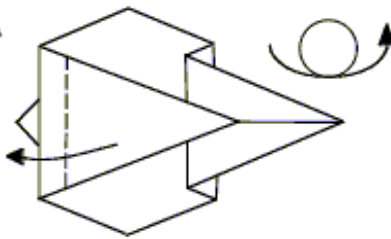

12. Fold all flaps along existing crease.

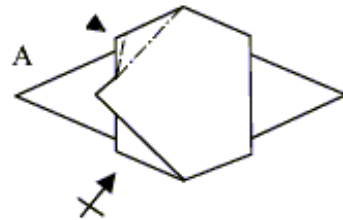

13. Inside reverse fold.

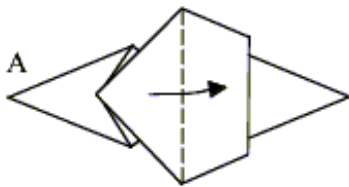

14.

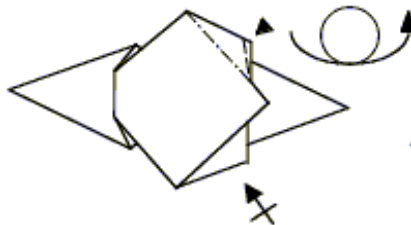

15. Inside reverse fold.

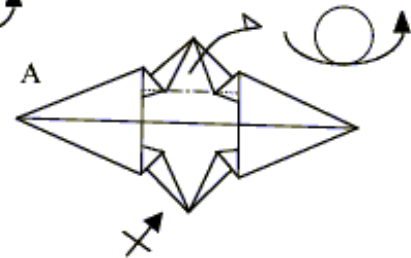

16. Fold point behind.

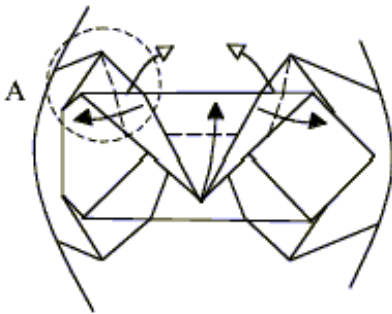

17. Release trapped paper and swivel fold on left and right. See close-up in step 17A.

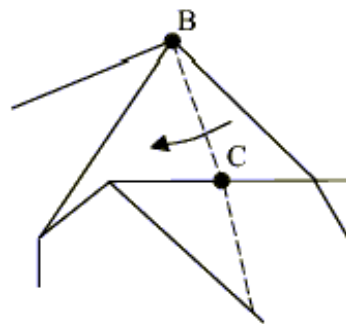

17A. Crease BC aligns with hidden edge on far side.

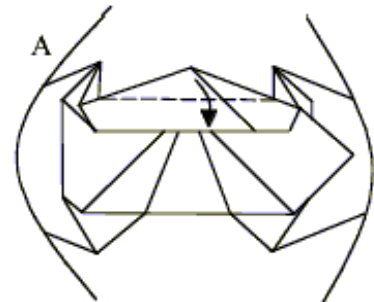

18. Fold aligns with hidden edge.

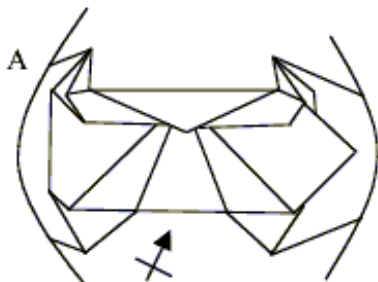

19. Repeat steps 17 - 18 on the bottom flap.

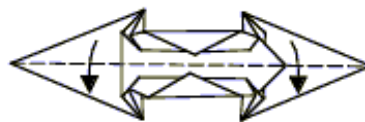

20. Fold in half.

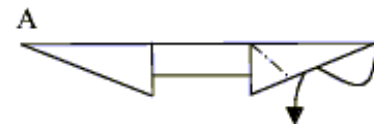

21. Inverse reverse fold. (See step 22.)

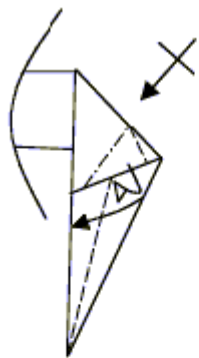

22. Inside reverse fold.

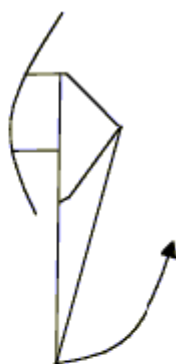

23. Inside reverse fold. See step 24.

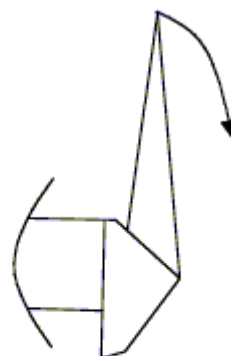

24. Inside reverse fold. See step 25.

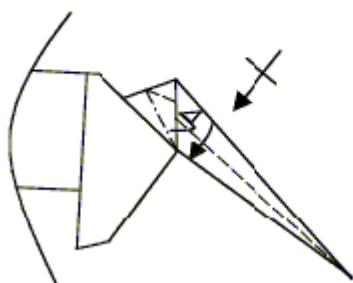

25. Inside reverse fold.

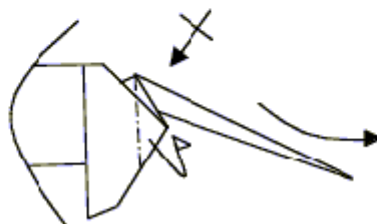

26. Blunt rear with mountain folds and shape tail.

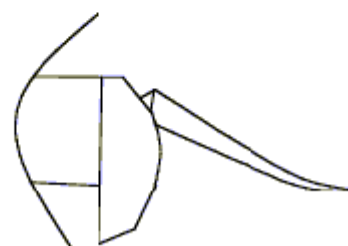

27.

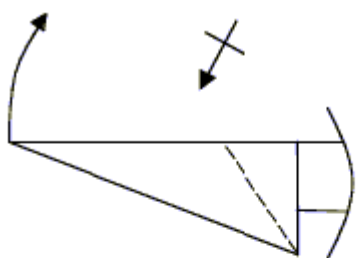

28. Valley fold the outer flaps.

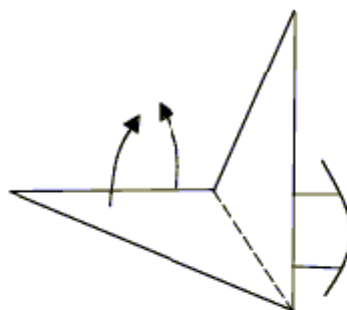

29. Outer reverse fold.

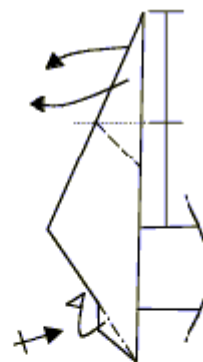

30. Outer reverse fold outer flap only.

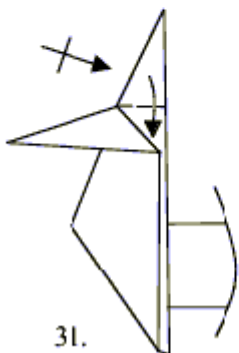

31.

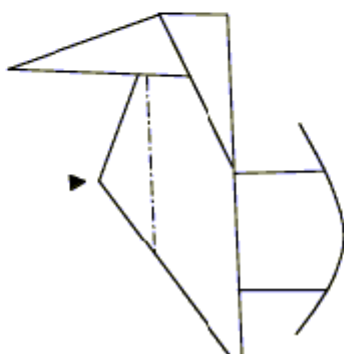

32. Open sink. (Making inside reverse folds on the hidden portions of the ear flaps will help keep all of the layers from separating.)

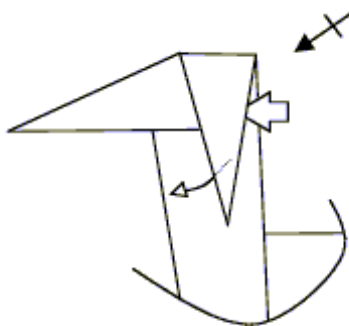

33. Open ear flap from side and squash flat. See steps 33A - 33C.

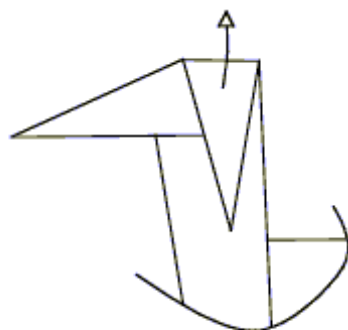

33A.

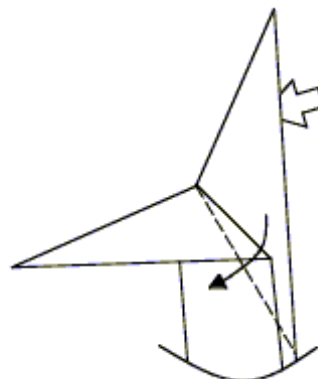

33B. Fold top layers only. Model will not lie flat.

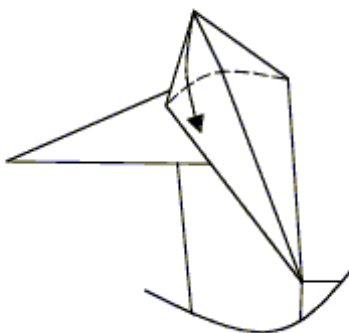

33C. Squash fold to flatten model.

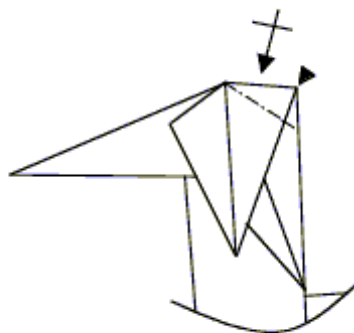

34. Inside reverse fold.

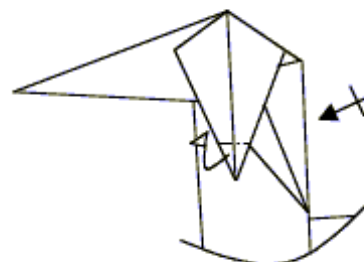

35. Blunt ear flaps with mountain folds.

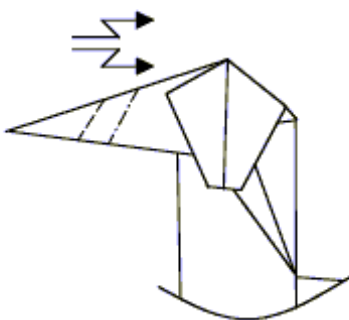

36. Crimp fold muzzle.

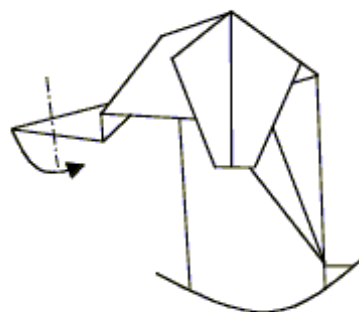

37. Blunt muzzle.

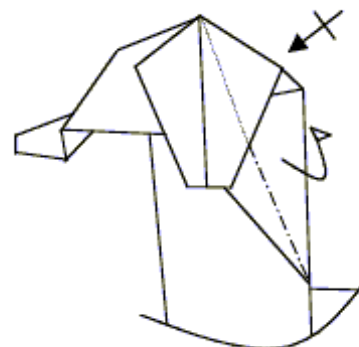

38.

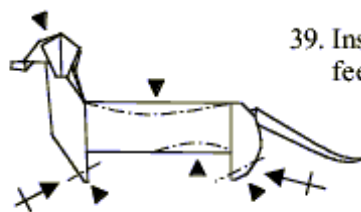

39. Inside reverse fold to form feet. Round and shape body.

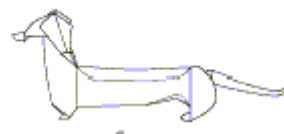

Skeleton of Octohedron I by Joshua Koppel

Use twelve (12) small squares.

The size of the square will be the same as the edge of the octahedron.

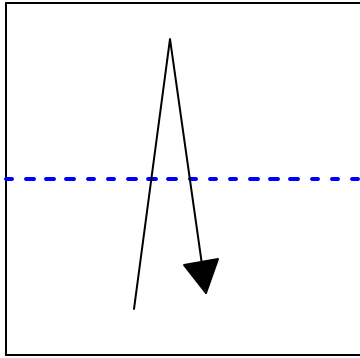

1. Fold and unfold.

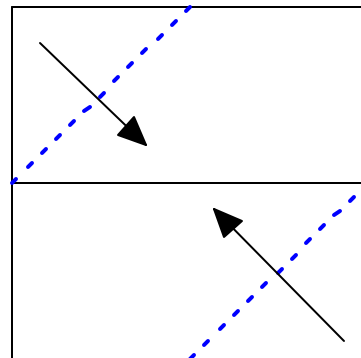

2. Fold opposite corners to center.

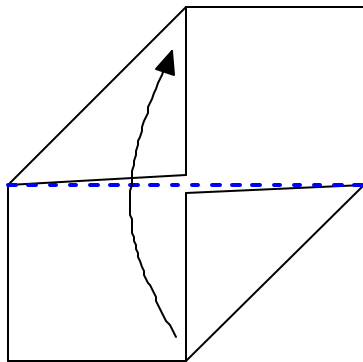

3. Fold in half

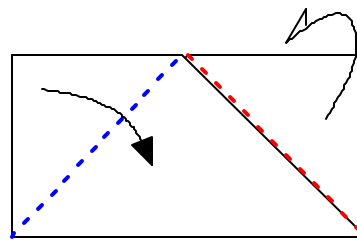

4. Bend tabs.

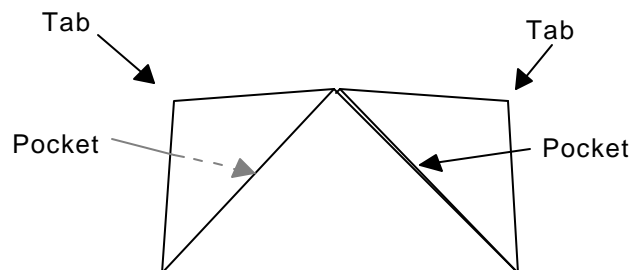

Make twelve (12) units. Four units each of three colors results in an octahedron like the one pictured.

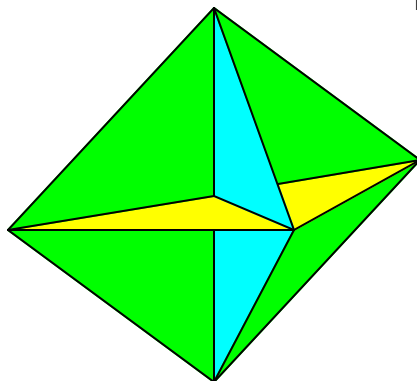

Sonobe Variation 2a: Zebra by Joshua Koppel

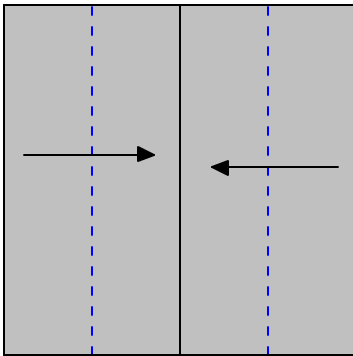

1. Fold edges to center.

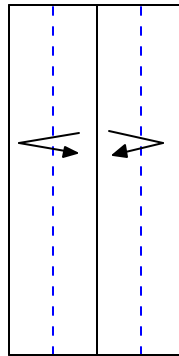

2. Fold and unfold.

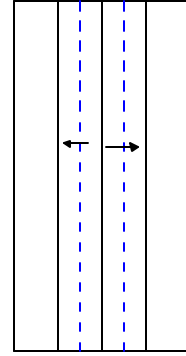

3. Fold edges outward.

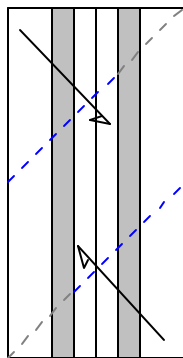

4. Tuck corners under flaps.

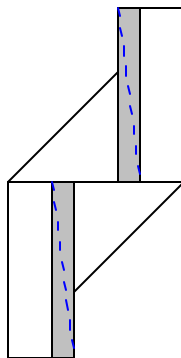

5. Fold edges over.

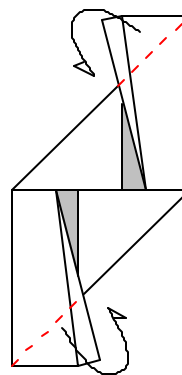

6. Fold corners behind.

