

Scaffold

Helping to support and maintain the world of origami

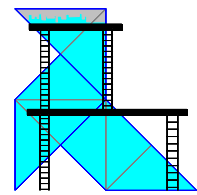

Happy holiday folding!

Hello, and welcome to the holidays issue. This is a season of holidays, Christmas, Channukah, Ramadan, Kwanza, Yule, etc., and so this issue brings some models appropriate for the season.

New Books

This month I picked up a number of Annual Collections from Origami-USA where they, and many other fine books were on an inventory-reduction sale. Check them out at <http://www.origami-usa.org>. I also stopped by one of the Asahiya Bookstores where I found the following books:

ORIGAMI DREAM WORLD by Toshikazu Kawasaki (ISBN 4-225-00096-4) (Japanese) (Also available at Kim's Crane <http://www.kimscrane.com>)

POLYHEDRON ORIGAMI FOR BEGINNERS by Miyuki Kawamura

CONTENTS

<i>New Books</i>	1
<i>Book Review</i>	1
<i>Origami in Chicago</i>	2
<i>Submissions</i>	2
<i>Back Issues</i>	2
<i>The Models</i>	2
<i>2D Dreidel</i>	3
<i>3D Dreidel</i>	4
<i>Space Ship</i>	6
<i>60E Star</i>	8
<i>Snail</i>	11

(Heart Warming Life Series) (ISBN 4-529-05347-6) (Japanese with English titles)

A modular book by Tomoko Fuse (ISBN 4-416-30103-0) (Japanese) A new collection of modulars by various designers including many by Paolo Bascetta and Mette Pederson.

SUPER ORIGAMI by Yamada Jibun (ISBN 4-7974-1481-2) (Japanese)

ORIGAMI DINOSAURS 1 by Fumiaki Kawahata (ISBN 4-416-30106-5) (Japanese) A new collection with many previously seen dinosaurs (Origami Dinosaurs 1 & 2) plus a few new ones.

Book Review

POLYHEDRON ORIGAMI FOR BEGINNERS by Miyuki Kawamura in the Heart Warming Life Series is not quite for beginners. Beautiful photographs and colored diagrams make this an easy book to follow, but some of the models could prove rather frustrating.

This book of modular polyhedra takes the reader on a tour of the various polyhedral shapes and a number of construction methods.

The first section is dedicated to Bricks. These are brick-shaped pieces open on both ends. There are also corner structures that can be glued to the bricks to finish off their ends. Completed bricks are glued to one another to create all sorts of constructions.

After Bricks, the reader is

introduced to Prisms, Anti-Prisms, Pyramids, and Dipyrramids. Of these, only the Dipyrramids are closed structures.

The next section of the book begins the discussion of Polyhedra. Units are diagramed for all of the basic Polyhedra. After the reader becomes familiar with the polyhedra, they are then introduced to Skeletons of Polyhedron. Again, units are diagramed for all of the basic shapes.

After polyhedra and their skeletons, the reader is introduced to Polyhedral Frames. The first of these, the Tetrahedral Frame, has trouble holding together, while the second calls for glue.

Next, is my favorite section, the Polyhedron Kit. This "Kit" consists of an edge unit used for all polyhedra, and special corners for all of the basic shapes. The results are beautiful, airy sculptures that look like they would not hold together, but hold quite tightly.

The Stars section introduces the reader to stellation, raised pyramids on the faces of polyhedra. These are truly beautiful constructions but their beauty is marred by the fact that the units do not hold together.

The book finishes with a short piece on spirals called Flutterwheels, and then two-dimensional polygon shapes called Tiles. The only use shown for the Tiles is to glue them as decorations on the faces of the polyhedra.

The inability of some units to

hold together could be very frustrating for any beginners who might buy this book. But even advanced folders like myself can find plenty of interest in this volume.

POLYHEDRON ORIGAMI FOR BEGINNERS has a cover price of ¥1200 (ISBN 4-529-03547-6). I found my copy at one of the Asahiya Bookstores. It should be available wherever fine Japanese books are sold and I expect to see it available online soon.

Origami in Chicago

CHAOS, the Chicago Area Origami Society, meets every month on the second Saturday of the month. Meetings are held at the Garfield Park Conservatory located at 100 N. Central Park Ave. The meetings run from 1:00 PM until 4:00 PM and are open to the public.

The next several meetings will be held on:

December 8, 2001

January 12, 2002

February 9, 2002

If you are ever in the Chicago area on these dates, please drop by.

Each meeting is always packed with folding, teaching, books, sharing, and just plain good fun.

Submissions

Scaffold wants you! Scaffold thrives on original designs from around the world. This past month has been pretty good with quite a few diagrams submitted. Some are in this issue, while the rest will be in the January edition.

All submissions will be included in future issues. It is my goal to provide a place for original

designs to be shared with as much of the origami world as possible. Therefore I will include any model submitted. It is not for me to judge what others might be interested in.

Submissions may be made electronically or by mail, but electronic submissions are easiest. To submit diagrams electronically, just send them through e-mail to scaffold1@aol.com and they will be included in the earliest possible issue. To send a submission by regular mail, send to:

Joshua Koppel
PO Box 641374
Chicago, Illinois 60664-1374

All submissions should include a statement giving permission for the model to be used in SCAFFOLD. At the end of this issue is a sample consent form. Feel free to use it if you are sending paper diagrams. For electronic submissions, just use it as a guide for what to say.

Back Issues

If you have come across this newsletter by way of a friend or other such source, you may still obtain all of the back issues.

Back issues may be found online at <http://www.origami4you.com> (just click on the Scaffold link). Make sure you check out the rest of the site while you are there. You can find diagrams and links to more origami sites than you can shake a paper crane at.

The Models

Another mixed-bag of models. On the holiday theme we have decorations and toys. We also have an alien space craft and a simple snail. Have fun folding.

2D Dreidel

This is a two-dimensional representation of a children's toy associated with the holiday of Channukah. This model can be used as a decoration.

3D Dreidel

I created this model last month when people asked for origami dreidels that worked. This is a two-piece model (both pieces are the same size); one for the spinner and one for the handle. This model really works.

Space Ship

Jim Adams discovered Scaffold and immediately sent in this spaceship. Jim has sent in some more models which will be in future issues. He maintains a website at <http://members.aol.com/jeadams1/origami.html>.

60E Star

This star, and its many variations, was created and sent in by David Petty. This is another model that makes a nice holiday decoration. More of Mr. Petty's creations will follow in future issues.

Snail

This model was designed by John Dombrowski of Chicago, Illinois, USA. Diagrams have appeared in the Origami USA Annual Collection 1993 but the diagrams were altered in the editing process so that they were slightly incorrect. The Snail appears correctly for the first time in this issue.

Dreidel by Joshua Koppel

Begin with the desired side down.

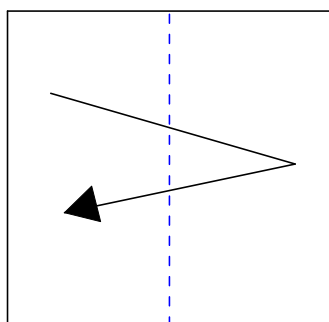

1. Fold in half. Unfold.

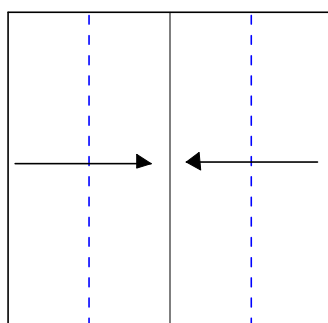

2. Fold edges to center.

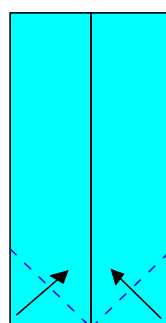

3. Fold bottom corners to center.

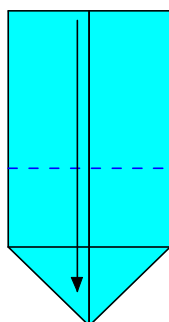

4. Fold top edge to bottom.

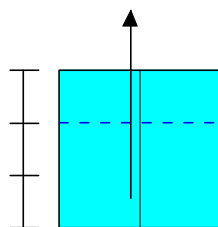

5. Fold 2/3 up.

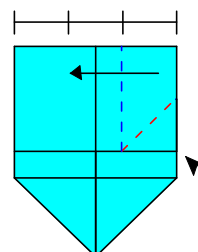

6. Fold 1/3 to center and squash.

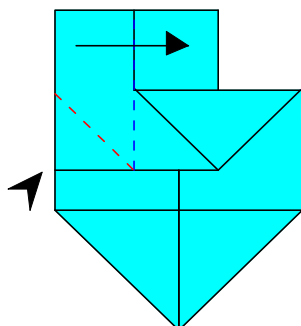

7. Fold 1/3 to center and squash.

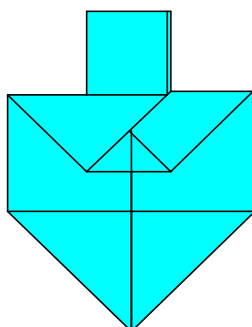

8. Turn over.

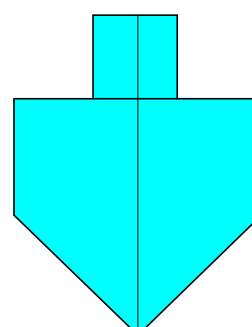

9. The completed Dreidel, ready for decorating.

Working Dreidel by Joshua Koppel

Begin with two preliminary bases of the same size.

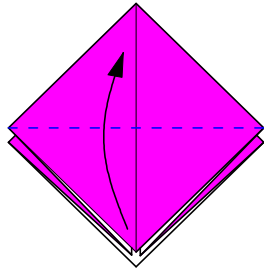

1. Fold front flap to top.

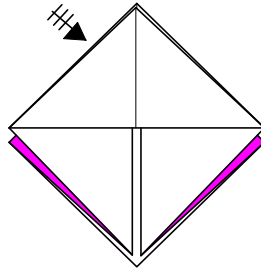

2. Repeat on other 3 sides.

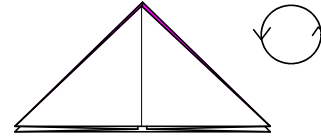

3. Rotate 180 degrees.

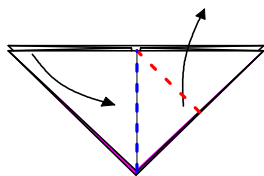

4. As you fold the mountain-fold, the left flap will swing over and make the model 3D.

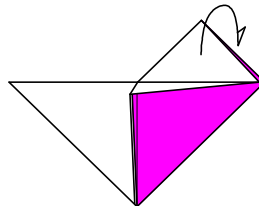

5. Tuck the flap behind and inside the model.

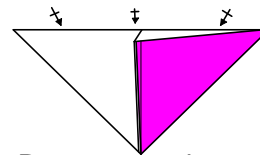

6. Repeat on other 3 sides.

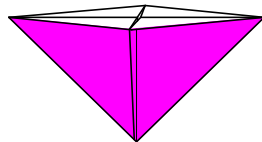

7. The completed Spinner.
You may decorate the top with the appropriate letters.

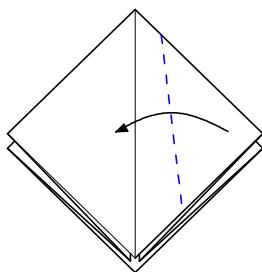

8. Use the other preliminary base. Fold a flap over.

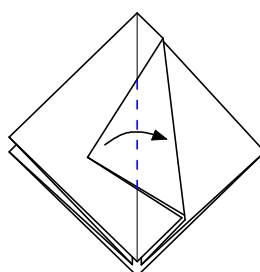

9. Fold flap along center line. 10. Unfold.

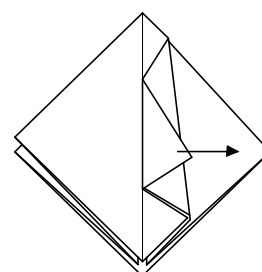

Working Dreidel by Joshua Koppel

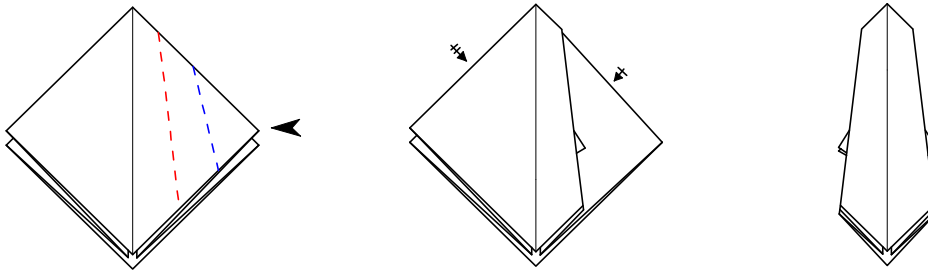

11. Sink along existing creases. 12. Repeat on other 3 sides. 13. The completed Stem.

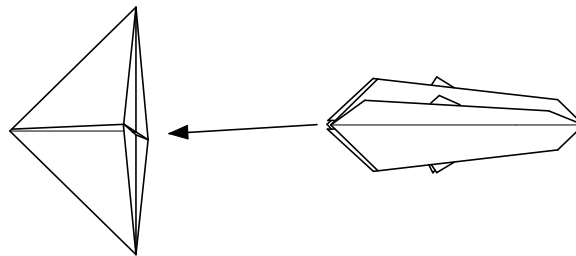

14. Open the Stem into an "X" shape. Slide the Stem into the center of the Spinner.

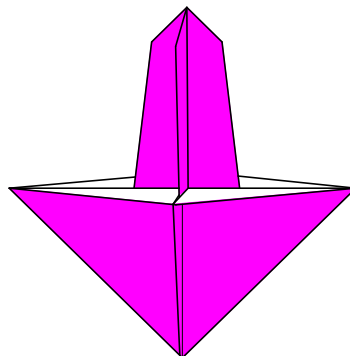

The completed Dreidel. Take it for a spin!

Alien Spaceship by Jim Adams

1

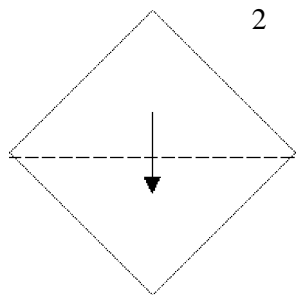

2

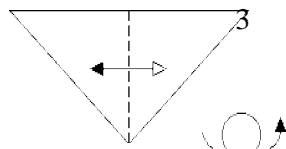

4

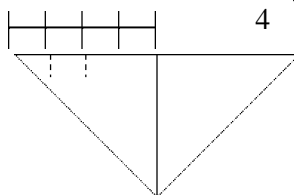

5

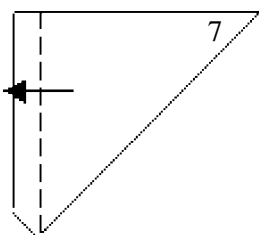

8

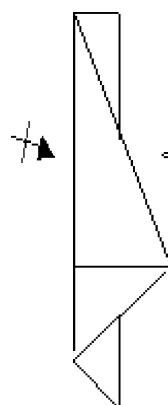

9

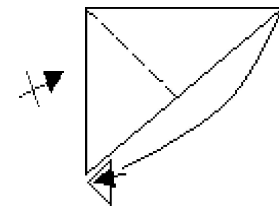

6

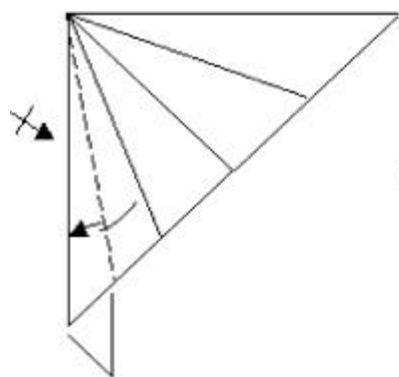
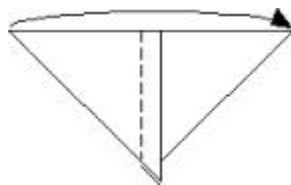

10.

11.

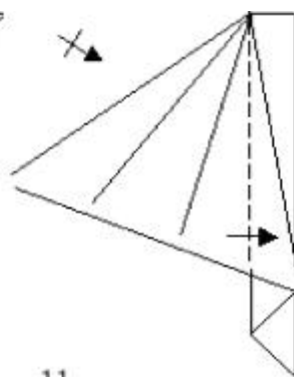

12.

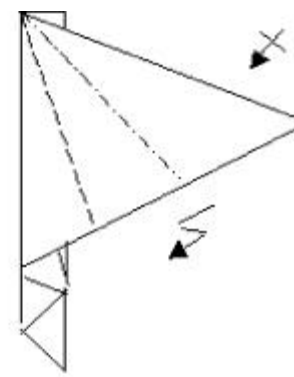

13.

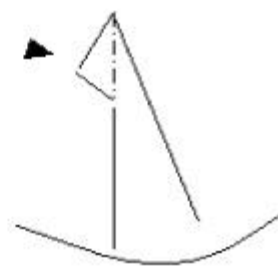

14.

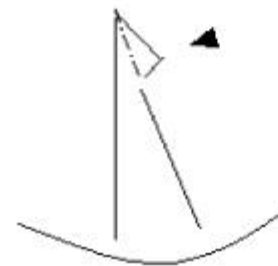

15.



16.

17

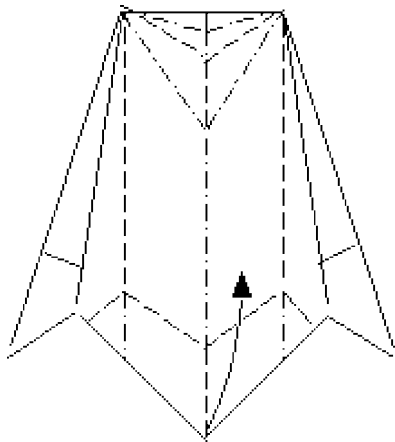

18

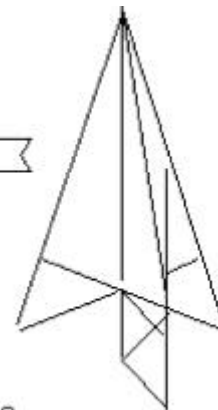
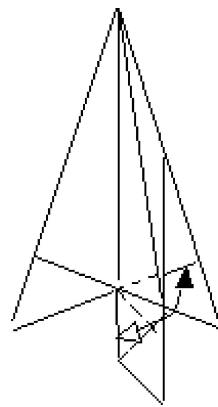

18.

19

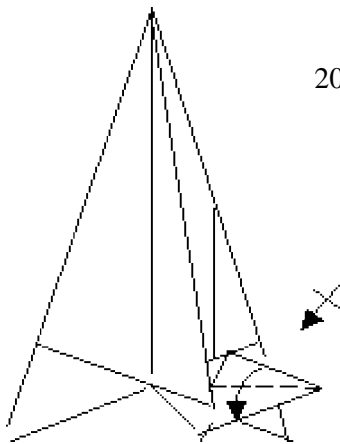

20

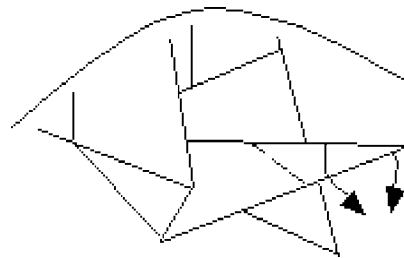

21

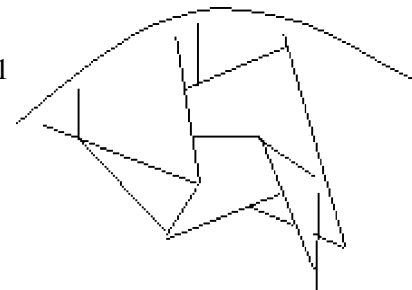

22

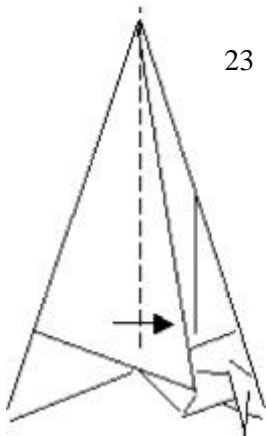

23

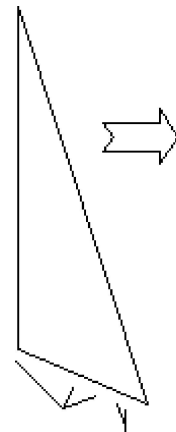

24

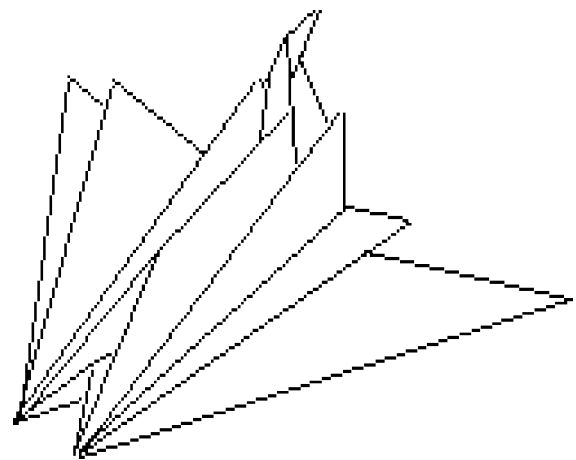

60 DEGREE STAR

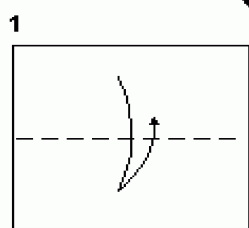

1
crease centreline

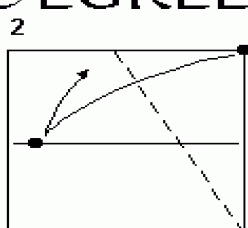

2
fold and return,
marked points meet

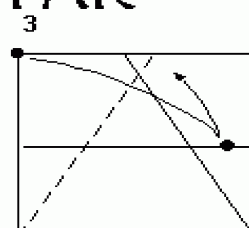

3
fold and return,
marked points meet

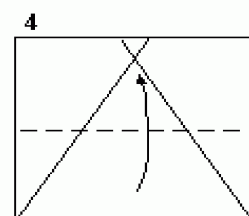

4
fold on centreline



5
fold and return
on existing creases



6
inside reverse fold

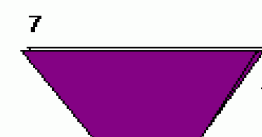

7
result, turn over

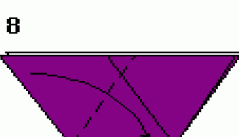

8
fold using existing
crease

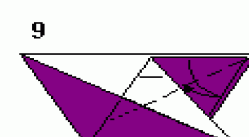

9
fold to outer edge
and return

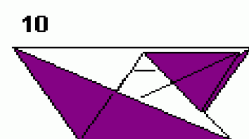

10
unit complete,
make 6

Assembly



A
rear flap of left unit goes behind
front flap of right unit
marked points meet

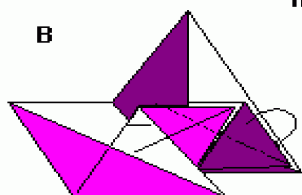

B
fold flap behind layers
in pocket using existing
crease

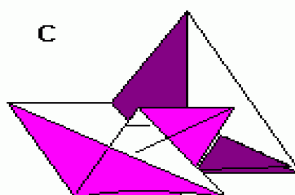

C
two units joined,
all 6 join similarly

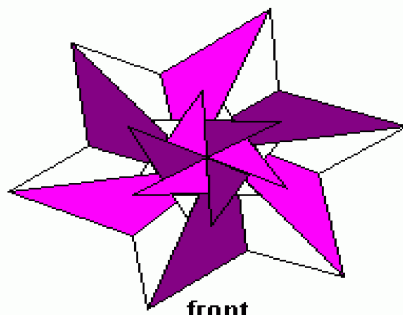

front

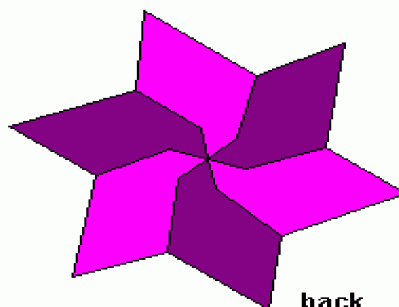

back

variation 1

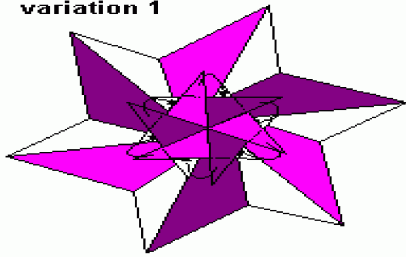

fold points over edge behind

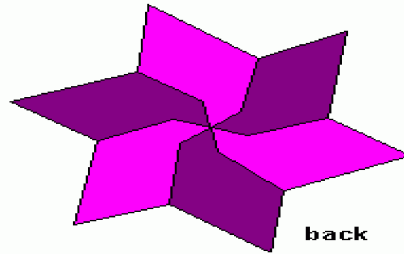
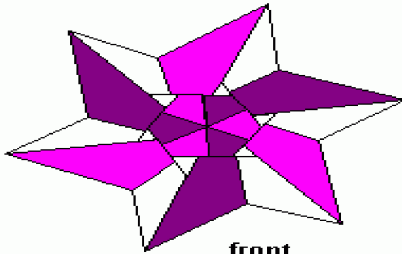

variation 2

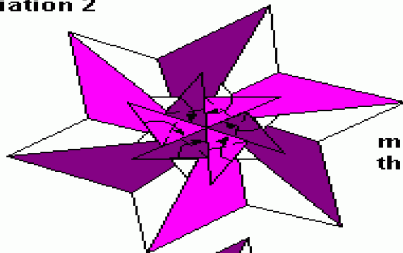

**make the creases one by one,
then fold all tips simultaneously**

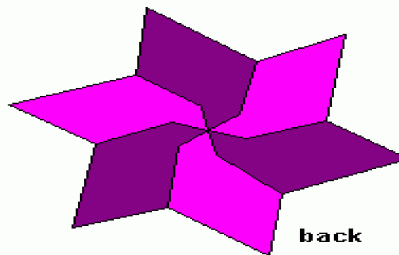
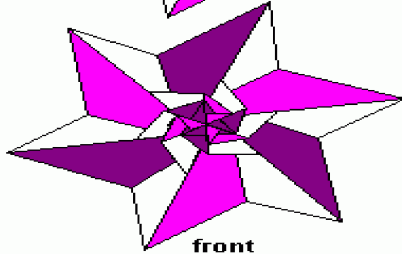

**variation 3
start with variation 2**

fold points over edge behind

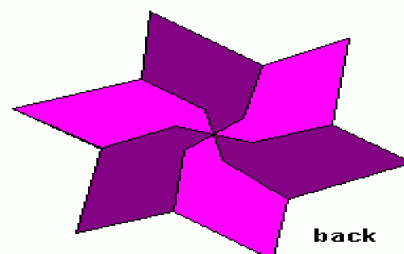
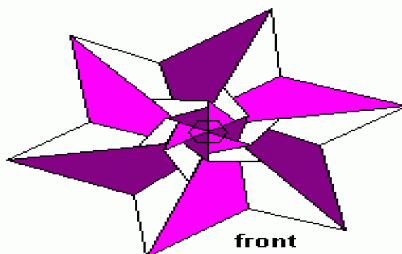
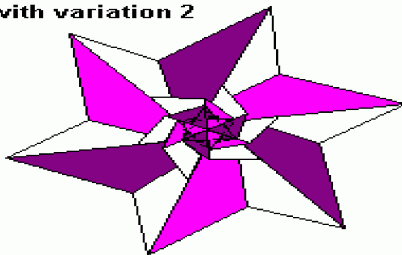

60 DEGREE STAR VARIATIONS

60 DEGREE STAR 1

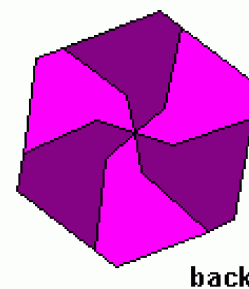
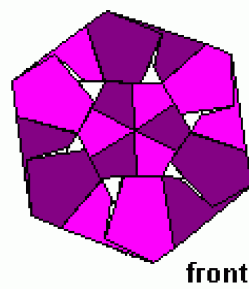
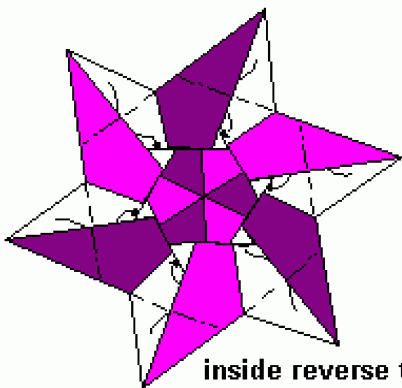
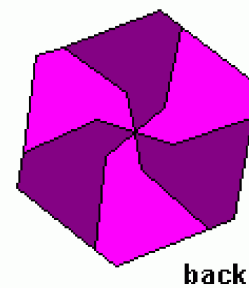
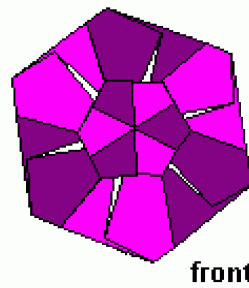
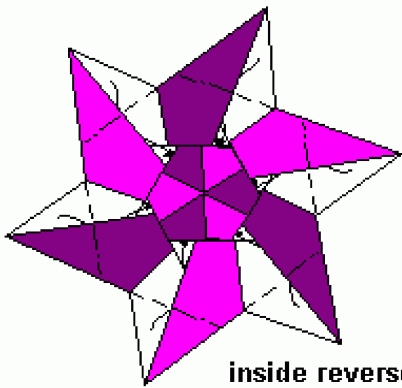
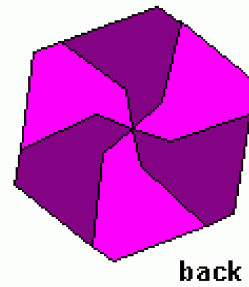
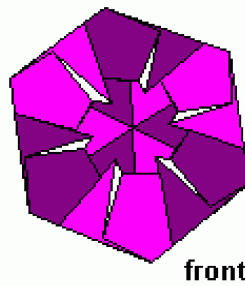
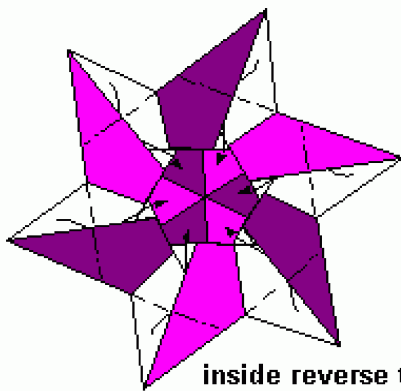
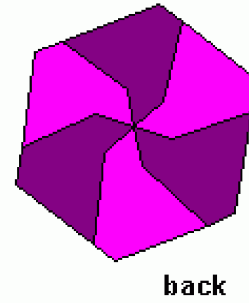
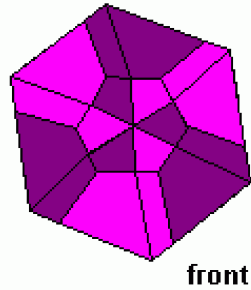
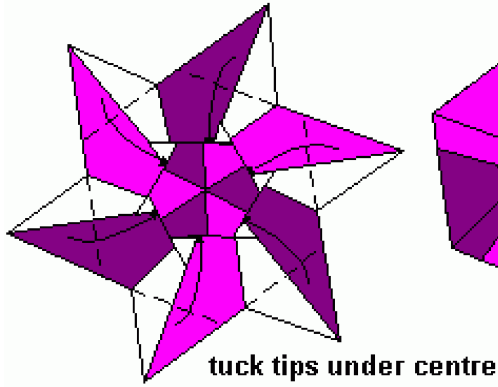

Snail by John Dombrowski

Begin with a colored waterbomb base.

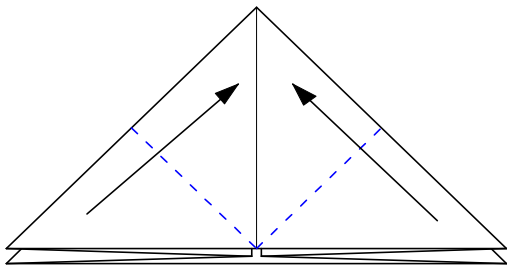

1. Fold corners to top.

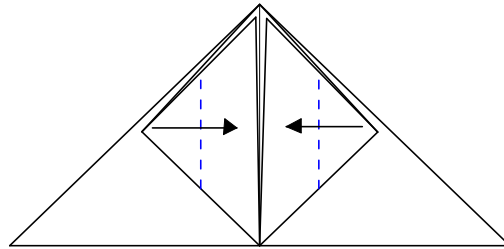

2. Fold corners to center.

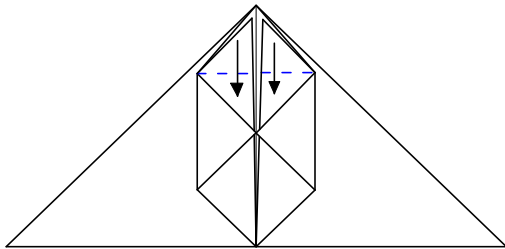

3. Fold points down.

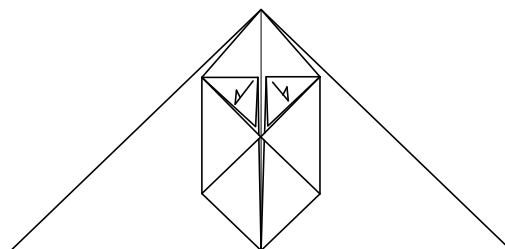

4. Tuck flaps into pockets.

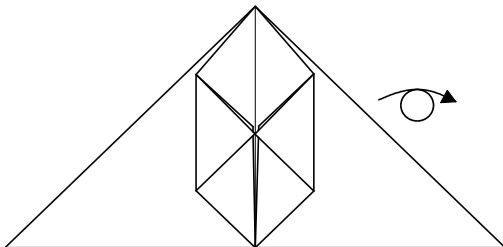

5. Turn over.

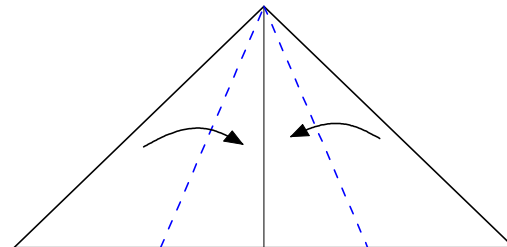

6. Fold edges to center.

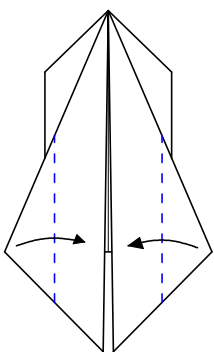

7. Fold side points to center.

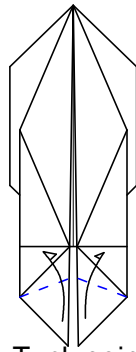

8. Tuck points into pockets.

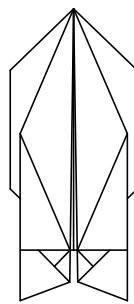

9. Turn over and inflate the shell.

